

## Solve Alignment and Vibration Problems With the Lock-Chock™

Revised September 03

**THE LOCK-CHOCK™ IS AN ADJUSTABLE SUPPORT SYSTEM DESIGNED FOR USE WITH ALL TYPES OF CRITICAL ALIGNMENT EQUIPMENT SUCH AS PUMPS, COMPRESSORS, GENERATORS, MACHINE TOOLS, FANS AND BLOWERS.**

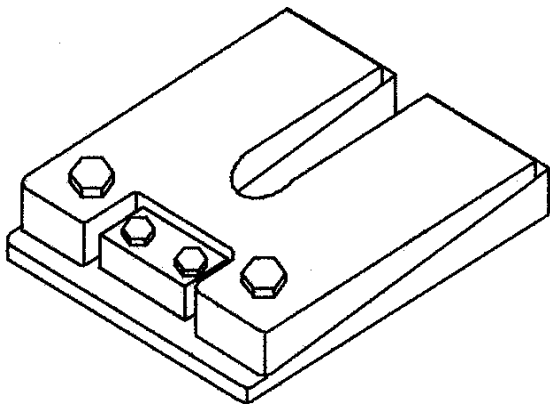

TOP VIEW OF THE LOCK-CHOCK™ SHOWING THE ANCHOR BOLT SLOT, THE LOCKPLATE, AND THE TWO HOLD DOWN BOLTS THAT LOCK THE TWO PLATES

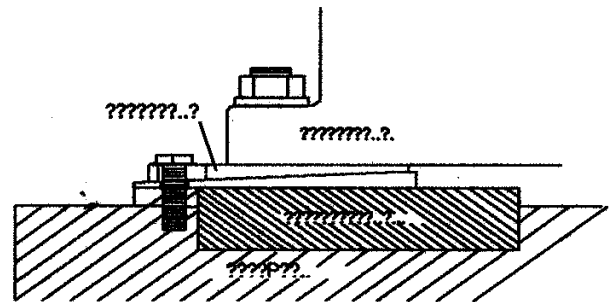

SIDE VIEW OF THE LOCK-CHOCK™ SHOWING THE TWO TAPERED PLATES THAT PROVIDE THE ADJUSTABILITY FEATURE. THE LOCK-CHOCK™ CAN BE USED

### BENEFITS INCLUDE:

HIGH STRENGTH COMPOSITE MATERIAL OR STEEL

60,000PSI COMPRESSIVE (COMPOSITE)  
PRECISION MACHINED  $\pm .001"$

DAMPENS VIBRATION

NO SHIMS TO RUST AND SWELL

MANAGE ALIGNMENT PROBLEMS

BETTER ALIGNMENT = LESS VIBRATION

CUSTOM DESIGNED PER EQUIPMENT FOOTPRINT

STANDARD THICKNESS IS 15/16 IN.

---

Robt. L. Rowan & Assoc., Inc. · 3816 Dacoma · P.O. Box 920760 · Houston, Texas 77292-0760  
Tel (713) 681-5811 · Toll Free (800) 231-2908 · Fax (713) 681-5815

Visit our website at [www.rlrowan.com](http://www.rlrowan.com)

© Copyright 1999 – Robt. L. Rowan & Assoc., Inc.